



YORA
SOLUTIONS

Tank Cleaning and Oil Separation

TECHNOLOGY PRESENTATION



Tank Cleaning

Oil tanks are containers designed for the storage of oil and its derivatives. These tanks come in various shapes and sizes, and they serve multiple purposes, including:

2. Industrial Storage: Large oil tanks, often found in refineries and industrial facilities, store crude oil and other petroleum products. These tanks are typically made of steel or reinforced concrete and can hold millions of gallons.

Oil tanks are equipped with safety features such as pressure-relief valves, vents, and sometimes secondary containment systems to prevent leaks and spills. They can be above ground or underground, with the latter requiring more stringent regulatory measures to prevent environmental contamination. Maintenance and regular inspections are crucial to ensure their integrity and safe operation.





[This Photo](#) by Unknown Author is licensed under [CC BY-SA](#)

Oil Tanks Composition

The composition left in an industrial storage oil tank before cleaning typically consists of a mixture of residues and sediments that accumulate over time. This leftover material can include:

Sludge: A thick, viscous substance made up of heavier hydrocarbons, dirt, rust, and other particulates that settle at the bottom of the tank.

Water: Due to condensation and other processes, water can accumulate at the bottom of the tank, often mixing with oil residues to form an emulsion.

Asphaltenes: These are heavy, complex molecules that precipitate out of crude oil and form a dense, tar-like substance.

Wax: Solidified paraffin waxes that can separate from the oil, particularly at lower temperatures.

Microbial Growth: In the presence of water, bacteria and other microorganisms can thrive, leading to the formation of biofilms and additional sludge.

Corrosion Products: Rust and other corrosion byproducts from the tank's interior surfaces can contribute to the residue.

This composition requires thorough cleaning to remove, as it can impact the tank's efficiency, lead to contamination of fresh oil, and potentially cause damage to the tank itself.

The unmanned Technology

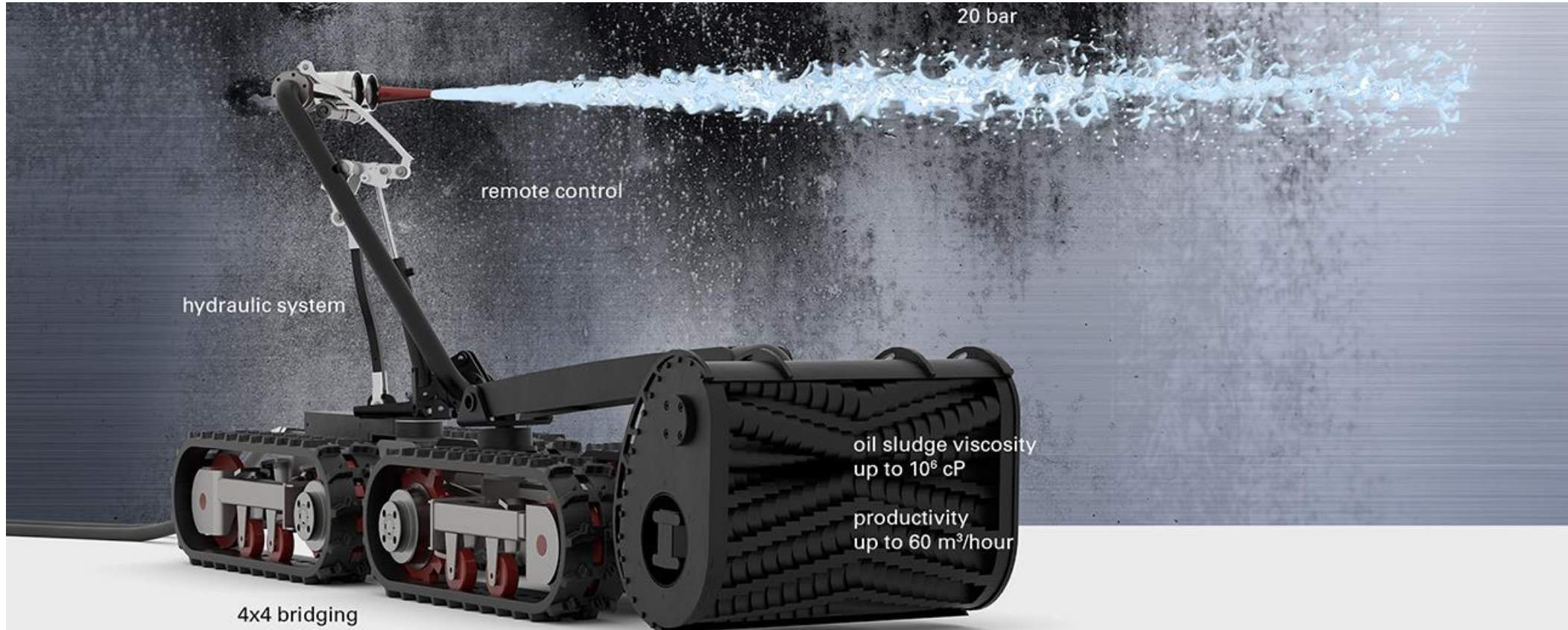

Oil Tank Cleaning

Industrial oil tank cleaning is a comprehensive process designed to safely and effectively remove accumulated residues, such as sludge, water, and other contaminants. The process typically involves several key steps:

Preparation

Inspection: Assess the tank's condition and contents.

Safety Measures: Implement safety protocols, including isolating the tank, ensuring proper ventilation, and using protective equipment for workers.

Oil Removal:

Draining: Pump out the remaining oil and transfer it to another storage unit or process it for reuse.

Sludge Handling: Utilize specialized pumps to remove as much sludge as possible.

Tank Ventilation:

Ensure the tank is properly ventilated to remove hazardous gases and vapors, preventing explosive atmospheres.

Cleaning Process:

Automated Cleaning: Use of automated systems like high-pressure water jets, rotating nozzles, or chemical cleaning agents to break down and remove remaining residues.

Sludge and Waste Disposal

Collect and transport the sludge and other waste materials to designated disposal or treatment facilities, following environmental regulations.

Tank Inspection:

Conduct a thorough inspection to check for any damage, corrosion, or other issues that need addressing before refilling the tank.

Repairs and Maintenance:

Perform any necessary repairs, such as fixing leaks, applying anti-corrosion coatings, or replacing damaged components.

Final Cleaning and Inspection:

Ensure the tank is completely clean and free of contaminants.

Conduct a final inspection and, if needed, a certification process to verify the tank is safe for use.

Recommissioning:

Once the tank is cleaned and inspected, it can be safely refilled with oil and returned to service.

This detailed process ensures that the tank is thoroughly cleaned, safe for use, and compliant with environmental and safety standards.

Oil tank contents Treatment



Containment: Ensuring that the oil tank is properly lined and contained to prevent leakage of oil and contaminants into the surroundings



Remediation: Implementing techniques to remove or reduce contaminants from the contents of the tank..



Separation: Separating different components of the oil tank contents, such as separating oil from water or solid particles, to facilitate proper disposal or recycling of each component.



Treatment Technologies: Utilizing various treatment technologies such as filtration, sedimentation, chemical oxidation, or bioremediation to treat the contents of the oil tank and reduce the concentration of pollutants.



Disposal or Recycling: Properly disposing of treated waste or recycling recovered oil for reuse, in accordance with regulatory requirements and environmental best practices



Our Solution

CONTAINERIZED REMOTE SOLUTIONS

One Shop Cleaning

Stop Tank

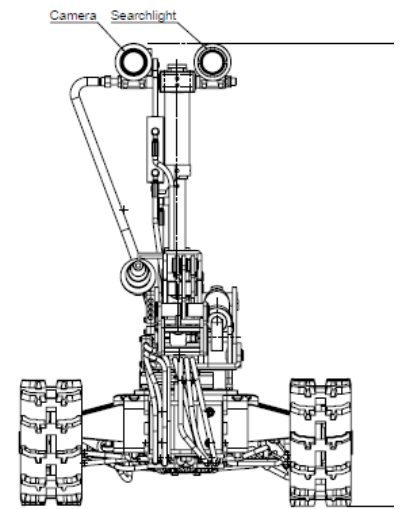
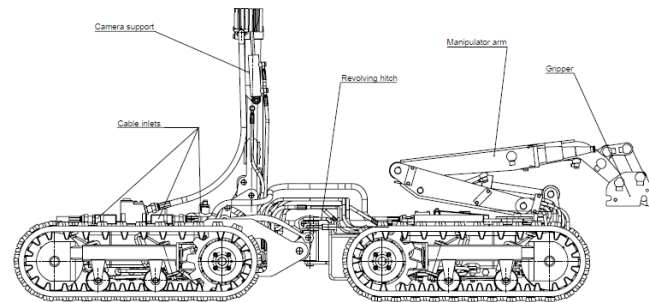
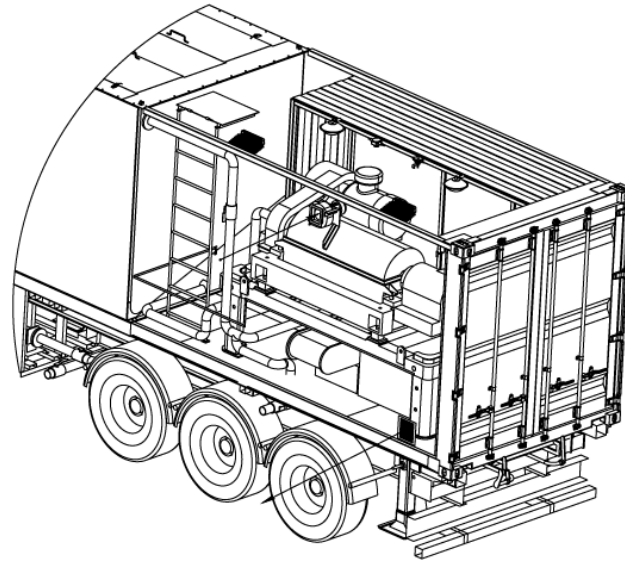

Technology

- discharge and transportation of diluted bottom sediments out of a tank
- recycling of washing out water for cleaning of a tank
- separation of cake (mechanical impurities) from the sludge
- oil recovery from the sludge.

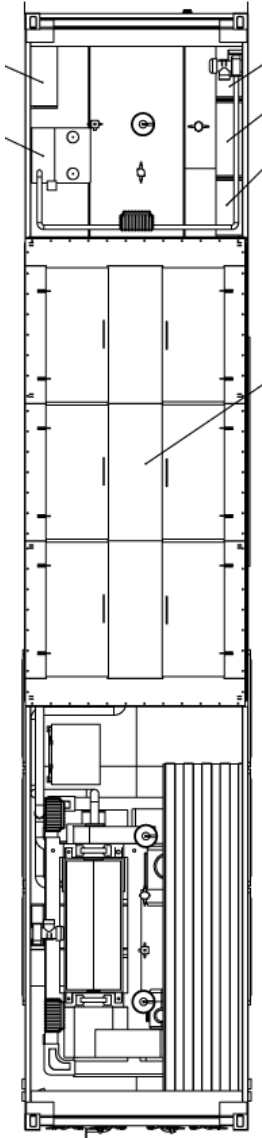

Equipment



40 Ft Container



Semi Trailer



Vacuum Pump

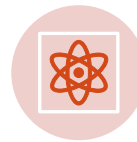

Gravity Dynamic Separator GDS



Centrifugal Decanter (Optional)



Belt Conveyor

The process

The complex is installed on a flat prepared base (soil, concrete pad, road, concrete slabs, etc.) before or after the oil tank's dike, the installation is leveled using hydraulic outriggers. Then stairs and railings are to be installed. Further, the complex is connected to the electrical grid (or diesel generator). After power is supplied, the power supply, instrumentation and fire alarm systems are started, and all devices and equipment are checked, the GDS is filled with 18CBM of water.

Vacuum pumps is installed and ready to start the pumping of the oil pit mix onto the GDS System.

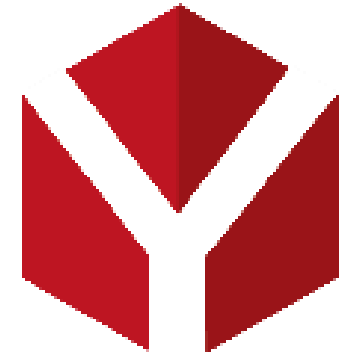

YORA
SOLUTIONS

Gravity Dynamic Separator

THE SYSTEM

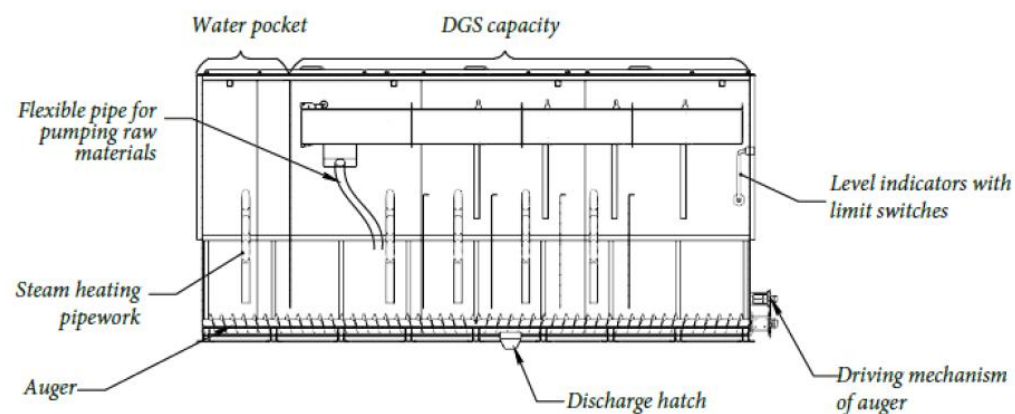

THE PRINCIPAL

In the GDS, sludge is separated into oil (hydrocarbons), clarified water, and flooded cake (solution of water and mechanical impurities). The GDS is equipped along the way with oil sludge (a mixture of water, oil, and cake) with special vertical partitions, which contribute (by lengthening the path of the flow entering it for processing) to a more complete separation of oil and water, as well as the solid phase contained in the sludge. Such a design forms sections in the GDS and ensures organized movement and separation of sludge into two liquid phases (water and oil) due to the fact that gradually the lighter phase (oil) is pushed to the top of the flow. The separated oil is collected on the GDS's surface using a skimmer device of a special design and is pumped out of it by a gear pump to the Customer's process system.

Gravity Dynamic Separator

SKIMMER

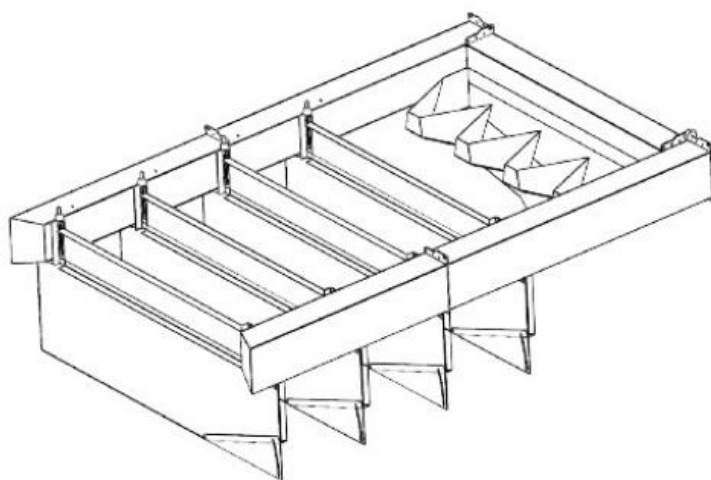

WATER RE-USE AND SEPARATION

Clarified (purified) water accumulates in the GDS's water "pocket" and is repeatedly (multiply) sent by means of the centrifugal multi-stage pump into the tank to dilute sludge or for re-sue and cleaning purposes. Flooded cake (solution of mechanical impurities and water) accumulates on the bottom of the GDS and is transported by a hydraulically driven screw to the discharge outlet located in the center of the bottom of the GDS, and then by a screw pump to a centrifugal decanter (two-phase horizontal centrifuge). The GDS can operate continuously with any amount of incoming sludge (for any flow of sludge) due to divided vertical 3 partitions, the upper part of which is connected to a floating pontoon, thereby ensuring a stable process of phase separation.

Gravity Dynamic Separator



The GDS is equipped with:

- skimmer device
- skimmer arrangement
- mechanical level gauge
- screw conveyor to unload mechanical impurities.
- Oil Suction Pump

Centrifugal decanter (two-phase horizontal centrifuge).

DECANTER

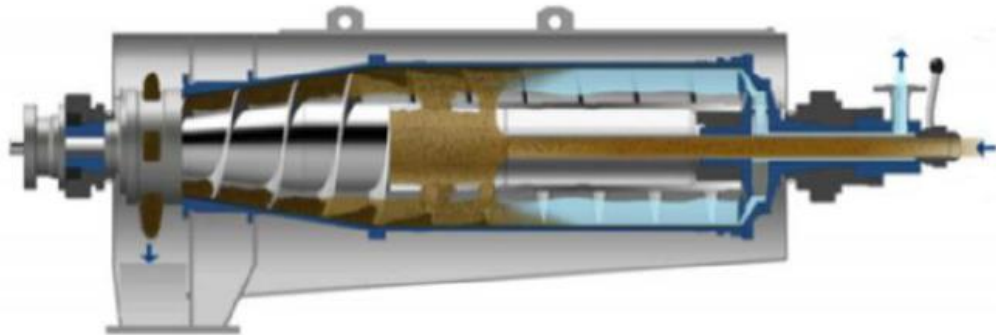

THE PROCESS (OPTIONAL)

The GDS requires 3CBM/HR without the decanter, the Centrifugal decanter serves the purpose of reducing water consumption and densifying the sludge cake.

1. Quality output with centrifugal decanter:
 - The average weight content of water in recovered oil is 5%
 - The average weight content of moisture in the solid residue intended for disposal is 40%.
2. Quality output without centrifugal decanter:
 1. The average weight content of water in recovered oil is 5%.
 2. The average weight content of moisture in the solid residue intended for disposal is 90-95 % or even more.

Centrifugal decanter (two-phase horizontal centrifuge).



DESIGN

Centrifugal decanter is designed for mechanical centrifugal separation of the mixture of liquid/mechanical impurities (two-phase). Separation occurs due to the different density of substances.

Optional Items

DEHYDRATOR WITH RECEIVING TANK



APPLICATION

Dehydrator is designed to separate mechanical impurities from water-oil emulsion and for the drainage of separated mechanical impurities.

Optional Items

CHEMICAL REAGENT SUPPLY NODE
EQUIPPED WITH DOSING PUMPS



APPLICATION

Chemical reagent supply node is designed to dose reagents (coagulants and flocculants) into the system, if necessary, and for qualitative separation of mechanical impurities from persistent oil sludge mixtures.

Flow Diagram

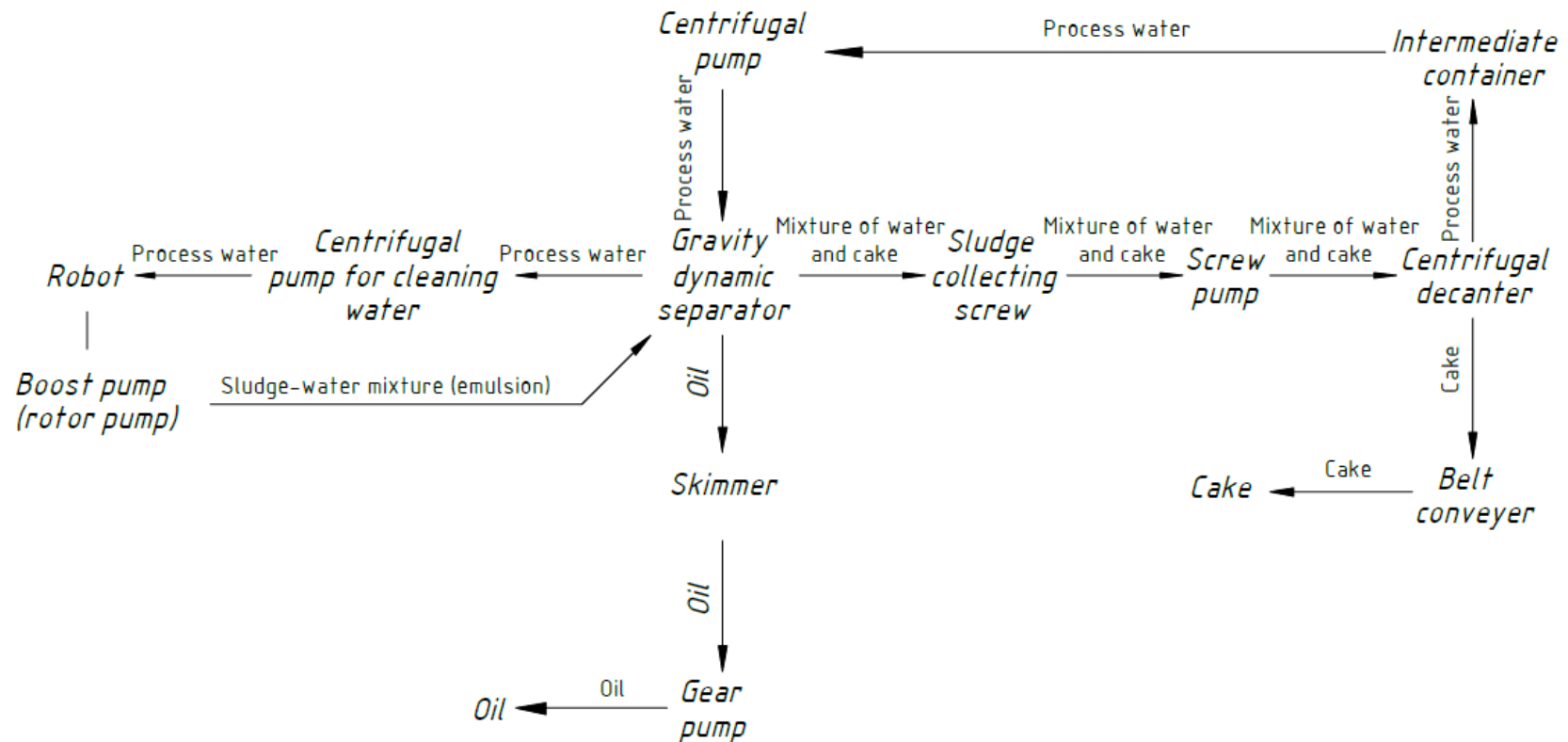

Optional Items added value*



- Oil: Basic Sediments & Water (BS&W) is less than 2 %;



- Water: Oil in water is less than 50 ppm;



- Solid Sludge: Oil content is less than 5 %, Solid content is more than 50 % and the remaining is water content.

Process Description

The Un-Manned Robot: Initially, the Robot is utilized to clean and extract the contents of the oil tank, encompassing crude oil, wastewater, and contaminants. This extraction efficiently removes the bulk of the material from the tank and pumps it to the GDS for separation.

Gravity Dynamic Separator (GDS): The extracted mixture is then directed to a gravity dynamic separator equipped with a skimmer. Within this separator, gravity segregates the components based on their densities. Solid particles and sediment settle at the bottom and are then directed towards the centrifugal decanter, while oil floats to the surface and is skimmed off, enhancing the purity of the recovered oil.

Centrifugal Decanter: Following the initial separation in the GDS, the residual mixture, consisting of a combination of water, some residual solids, and possibly traces of oil, undergoes further processing in a centrifugal decanter. Here, centrifugal force effectively separates the remaining components. Water, free from contaminants, is returned to the GDS for potential reuse, promoting water conservation efforts. Meanwhile, the denser sludge cake, comprising primarily solids, is directed to barrels or bags for appropriate disposal as waste.

This comprehensive approach ensures the efficient treatment of oil pit contents, effectively recovering oil for potential reuse, minimizing environmental impact, and promoting sustainable resource management practices by reducing water consumption.

Technical details

GDS

volume: 18 CBM;

Performance: from 30 to 43 cbm per hour. (depending on viscosity and other characteristics of oil sludge);

A metal container with a double steel wall with a layer of insulation (the upper part (roof) is made of hatches that allow maintenance of the GDS and visual control of the technological process);

CENTRIFUGAL DECANTER

Allows to remove mechanical impurities of more than 25 microns

Capacity, max. 40 m³/hour

Speed 3200 RPM (regulated with a help of a frequency converter)

The electric power of the main motor is 30 kW, electric power of the auxiliary motor 7.5 kW

Protection from aggressive fluids

Technical details

BELT CONVEYOR

Designed to unload mechanical impurities from the horizontal centrifuge into barrels or big-bags

40 FT CONTAINER

ISO container

12.19 (L) x 2.44 (W) x 2.591 (H) m

Net weight 3,800 kg

It is equipped with an additional door , stairs with handrails, a slider unit that allows to enlarge useful space of the container



20 bar

remote control

hydraulic system

oil sludge viscosity
up to 10^6 cP
productivity
up to 60 m³/hour

4x4 bridging

Thank You

YORA SOLUTIONS FZCO
info@yora-solutions.com
Dubai, UAE